

Slope Detector IV

Installation Instructions

Slope Detector IV Specifications:

Measurement Range	± 20°
Resolution	0.1° (0 to 9.9), 1° (10 to 20)
Operating voltage	9 to 32 VDC
Sensor Operating current (Nominal).....	150mA(12V) 50mA(24V)
Display Operating current (Nominal)	250mA(12V) 160mA(24V)
Operating & Storage Temperature	-40° C to +70° C
Set-point Range	0° to 20° (absolute value)
Relay Output.....	Operating Voltage @ 1A Max



Caution: Before attempting any installations or repairs, assure that the vehicle ground terminal is disconnected at the battery.



For technical assistance call:

(800) 368-3075

1404 N. Marshall Ave. El Cajon, CA 92020

Installation of Sensor Unit:

Caution: Before beginning the installation assure that the vehicle ground terminal is disconnected at the battery.

Preparation: The trailer must be parked on a level surface. Place a level on the axel where the Sensor Unit is to be mounted to make sure the axel is level. Care must be taken to place the Sensor Unit in a location that will not come in contact with the trailer frame or suspension components when the trailer is loaded and in operation.

Trailers with air bag suspensions: Deflate the air bags then check for proper Sensor Unit clearance at the mounting location.

Step 1.

Assemble the trailer sensor assembly as shown below. Observe the arrow indication shown on the sensor label indicating the front of the trailer. Insert each of the two - 5"x 1/2" U-bolts from the bottom of the axle through the sensor mounting plate. Place the flat washer and 1/2" Nylock hex nut on each of the four bolts and tighten down. The side view of the sensor assembly mounted on the axle is shown below in figure 1.

Note: Two connections are required from the sensor assembly to the trailer electrical system, (one black wire and one white wire). These electrical connections are critical elements of the total system performance, and care must be taken to protect them from exposure to road wash, road salt, grime, and debris. All connections should reflect and adhere to SAE and IPC/WHMA-A-620 installation recommendations.

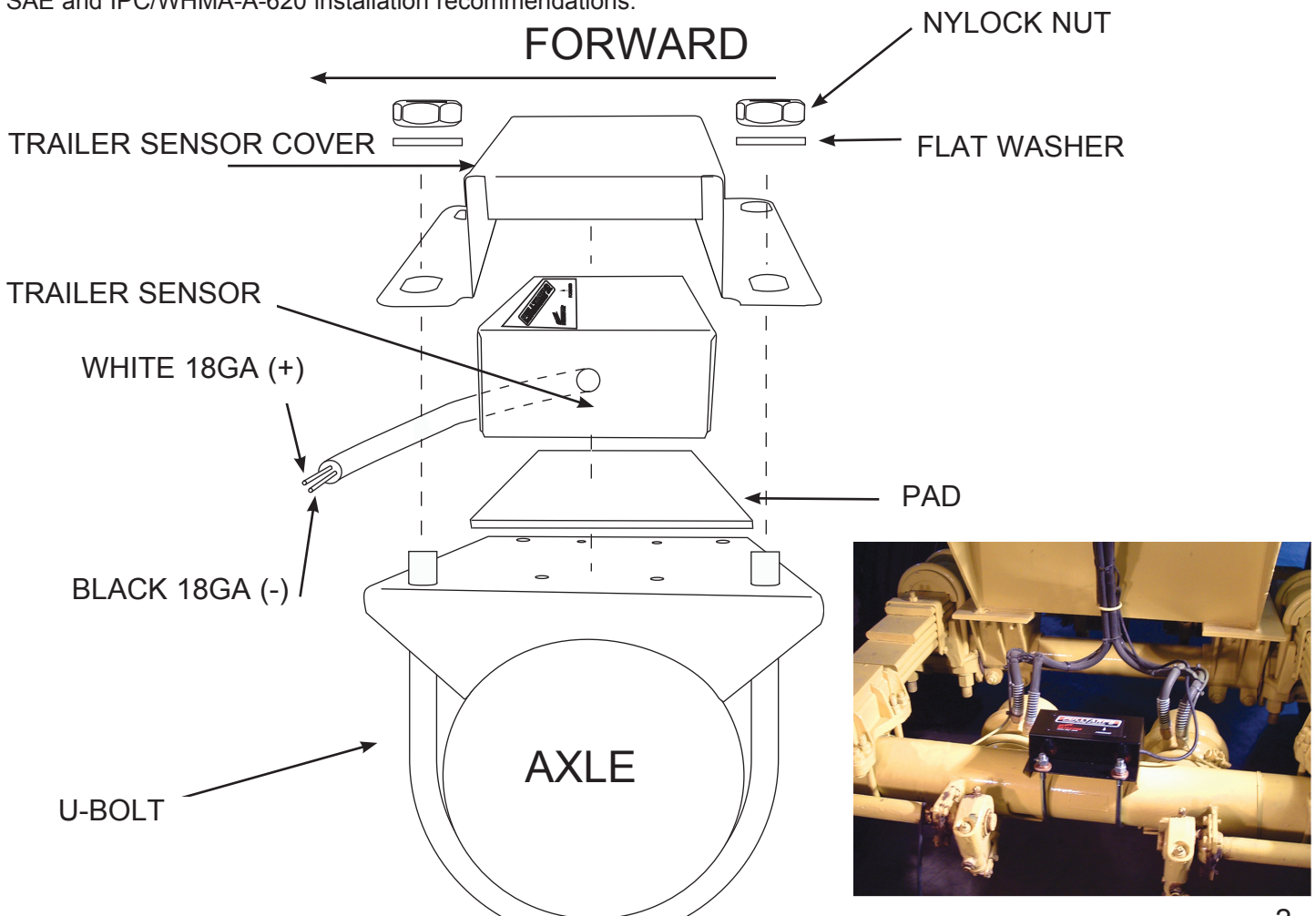

Figure 1: Side view of sensor assembly mounted on the axle.

Step 2.

Locate a power source (9V-32V) within the trailer harness. The tail lights/running lights are a suitable source and are located near the rear axle. Use a volt meter or test light to identify the wire that will have power when the lights are turned on. Note: Do not use the brake light circuit. **Be sure that the wire from the trailer sensor is long enough and routed properly so that it will allow full suspension travel when the trailer is in use. Allow enough slack for the wire to be routed away from any pinch points and secured to the wire and or air line bundles.** Tap into the lighting circuit with the Mini fuse holder using the Scotchlock 567 tap that is provided. Seal the Scotchlock 567 tap with RTV silicone or other waterproof sealer. Insert the 3 amp Mini blade fuse, (provided) in the fuse holder and snap the weatherproof cover over the fuse. Connect to the white wire of the sensor unit to the fuse holder. (See Wiring Diagram on Page 7). Use crimp type connectors that are properly sized for the wires being crimped. The crimp connectors should be the type that incorporates heat shrink (butt connector), or equivalent to protect and seal the connection in a harsh environment. Crimp using only the prescribed crimping tool for the connector selected. Seal the connection with RTV silicone or other waterproof sealer.

The trailer lights will need to be turned on for safety during the dumping process.

Alternate trailer power source: The blue wire that feeds power to the ABS system is an auxiliary power source (9V-32V) within the trailer harness that will be an ignition "on" power source. Use the Scotchlock 567 tap splice to connect one end of the mini fuse holder to the blue wire that leads to the ABS control module circuit. Seal the Scotchlock 567 tap with RTV silicone or other waterproof sealer. Insert the 3amp Mini blade fuse, (provided) in the fuse holder and snap the weatherproof cover over the fuse. Connect to the white wire of the sensor unit to other end of the fuse holder. (See Wiring Diagram on Page 6). Use crimp type connectors that are properly sized for the wires being crimped. The crimp connectors should be the type that incorporates heat shrink (butt connector), or equivalent to protect and seal the connection in a harsh environment. Crimp using only the prescribed crimping tool for the connector selected. Seal the connection with RTV silicone or other waterproof sealer.

Step 3.

Connect the black wire from the sensor to a good ground connection on the trailer making sure the same care and considerations are given to protect the connection. A crimp on ring loop connector and self drilling screw are provided.

Step 4.

Check to assure that all cables are appropriately tied off to avoid catching road debris and sagging.

Installation of the MAC valve:

Included with your Slope Detector IV you will find a MAC solenoid air valve. This will either be a 12V or 24V MAC valve depending on the vehicle system voltage. **Check that you have received the proper voltage rated MAC valve before continuing.** See figure 2 below for the inputs and outputs of the MAC valve. There are two wire connections and three air ports on the MAC valve that are required for proper operation.

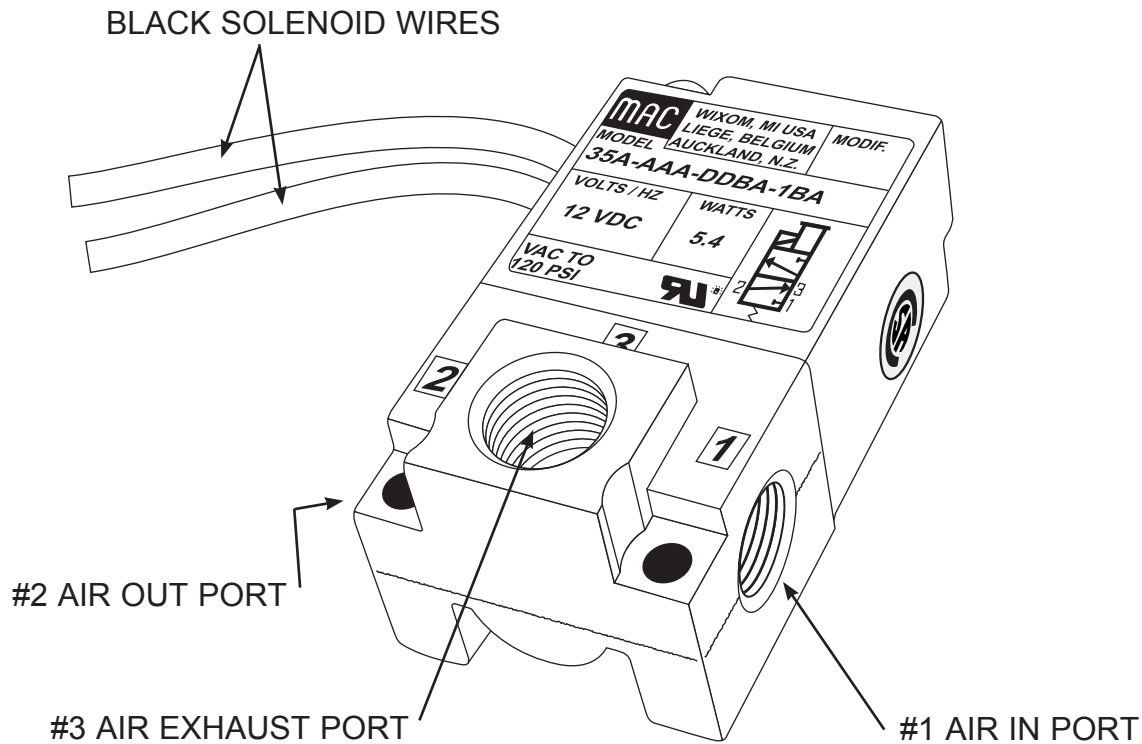

Figure 2: MAC valve air solenoid.

Step 5.

Remove the necessary in-cab dash panel(s) to gain access to the manual PTO control valve and air lines. Mount the MAC valve near the PTO air lines, using the two mounting holes and self tapping screws (not included), or tie wrap to existing cables etc.

The surface of the MAC valve regularly reaches 120° F; verify that the MAC valve is not touching any wires or hoses.

Step 6.

Connect one of the black wires from the MAC valve to a vehicle ground. If a greater length is required, 18 gauge GXL wire is recommended.

Step 7.

Refer to the wiring diagram on page 8 for MAC valve air port connections to the tractor airlines. The MAC valve is designed to accommodate ¼" OD plastic hose only.

Installation of the Display Unit:

Step 8.

Disconnect the vehicle battery ground. Should be done before starting installation. See page 1.

Step 9.

Determine the desired location of the display unit inside the cab of the vehicle. The mounting bracket provided allows for “under the dash” mounting or “on top of the dash” mounting depending on user preference. Three electrical connections are required from the display unit to the vehicle chassis. (See Wiring Diagram on page 8) Use the appropriate bodybuilders manual to locate an auxiliary power source (9V-32V) that will be ignition “on”. The ignition switch usually provides auxiliary ignition “on” power sources. The switched circuit for running lights can also be a power source.

Note: It is not recommended that the cab or trailer unit be connected directly to the battery. Do not connect the cab unit directly to the main power supply on the fuse panel. Avoid connecting to any fan or climate control circuit.

Connect the Mini fuse holder to the power source. Insert the 3amp Mini blade fuse, (provided) in the fuse holder and snap the weatherproof cover over the fuse. Connect the red wire from the display unit to the fuse holder using butt connector, or equivalent. (See Wiring Diagram on Page 8). Use crimp type connectors that are properly sized for the wires being crimped. The crimp connectors should be the type that incorporates heat to protect and seal the connection in a harsh environment. Crimp using only the prescribed crimping tool for the connector selected. Seal the connection with RTV silicone or other waterproof sealer.

Step 10.

Connect the black wire from the display unit to a solid ground location in the cab.

Step 11.

Connect the white wire from the display unit to either of the black wires of the MAC valve (See Wiring Diagram on page 8), using butt connector, or equivalent. Connect the second black wire from the MAC valve to a solid ground location in the cab. Be sure that connections reflect and adhere to all SAE and IPC/WHMA-A-620 installation recommendations.

Step 12.

Check to assure that all wiring is appropriately tied off to avoid pinching and damage

Step 13.

Remove each of the ½” machine screws on either side of the display panel mounting bracket. Remove the mounting bracket from the assembly. Use this bracket to mark hole locations where the display panel will be installed. Drill pilot holes using 5/32” drill. Install the mounting bracket using the 2 provided #10 x ¾” metal screws. Re-attach the display panel to the mounting bracket with the ½” machine screws.

After finishing all component installations re-attach the vehicle battery ground.

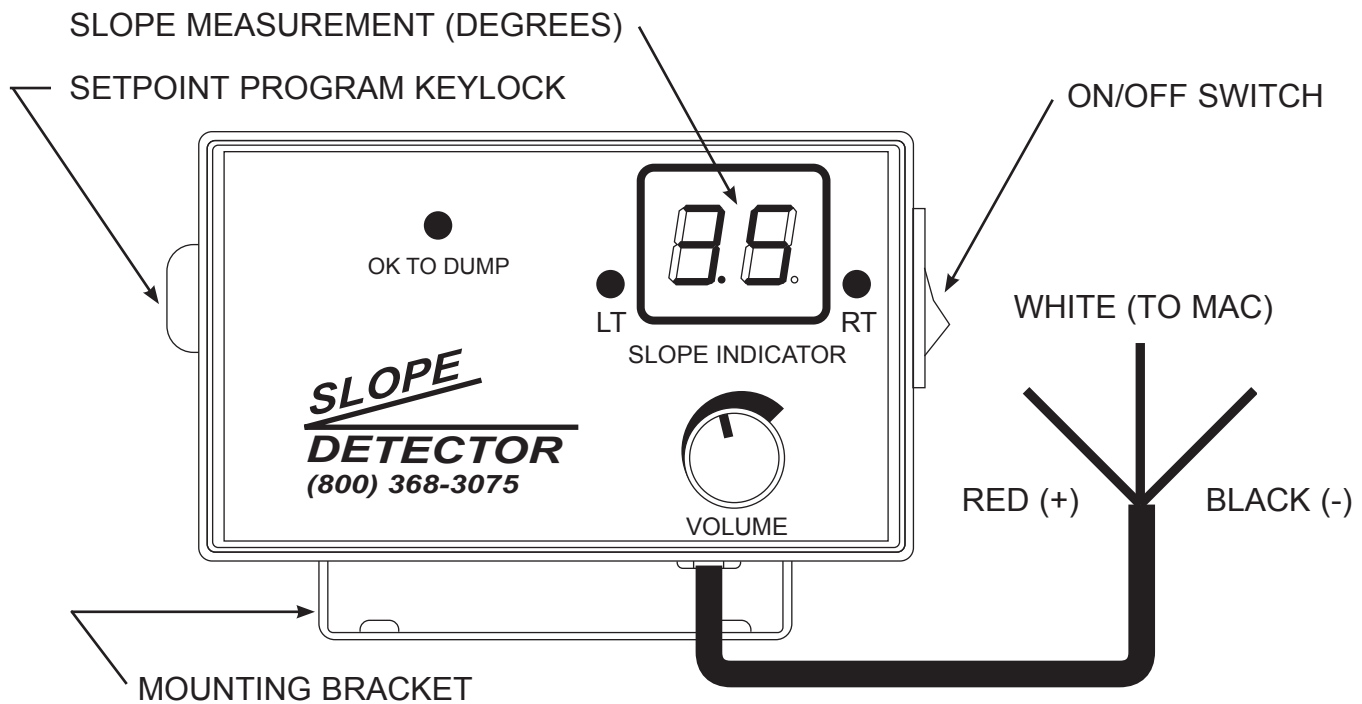

Figure 3: Display panel.

Step 14.
Display Unit Functionality:

Operating the display unit – Move the power switch of the display unit to the on position (see figure 3). The display will flash “ Slope Detector 4” and immediately start displaying the measured readings of the axle incline in degrees. If the measured reading is less than the programmed set-point, the supply voltage will be provided to the MAC valve allowing the air line to open. If the measured angle of incline exceeds the programmed set-point, the output supply to the MAC valve will be removed, closing the air line. There will be a 5 second delay after the measured angle falls below the set-point, before the MAC valve is re-enabled.

Changing the set-point – The Slope Detector IV will arrive with a default set-point of 6.0°. It is strongly recommended that you contact your trailer manufacturer for their recommendation on tilt limit before the unit is put into service. If your trailer manufacturer cannot provide that information, it is suggested that a conservative setting be used as a starting point. Pull the empty trailer up on to a 4” thick block and read the display on the cab unit for an initial reference point. This is not meant to be your initial setting, only a reference point. If a different set-point is desired, perform the following to change the set-point. Insert one of the two keys provided into the set-point program lock as shown in figure 3. If a lower incline angle is required turn the key to the left, if a higher angle is required, turn the key to the right. The message “Change set point” will flash briefly across the display. The current set-point reading will be displayed. By turning and holding the key to either the left or right, the set-point may be adjusted from 0.0° to 20°. When the desired set point is reached, remove the key. The unit will save the new set-point and return to angle measurements after 5 seconds displaying the message “ok”.

System Bypass - During the operation of changing the set-point, if the key is turned to the right and held after 20° the display will read bP, indicating that the system will be bypassed. When the set-point has been programmed for the bP setting, the air line will always be enabled. The system will no longer operate to limit the tilt angle. This setting will allow for the tractor to operate a trailer with no axle sensor unit installed. **WARNING: The set point must be reprogrammed when the tractor is again mated to a trailer equipped with a Slope Detector IV.**

Slope Detector IV Trailer Wiring Diagram

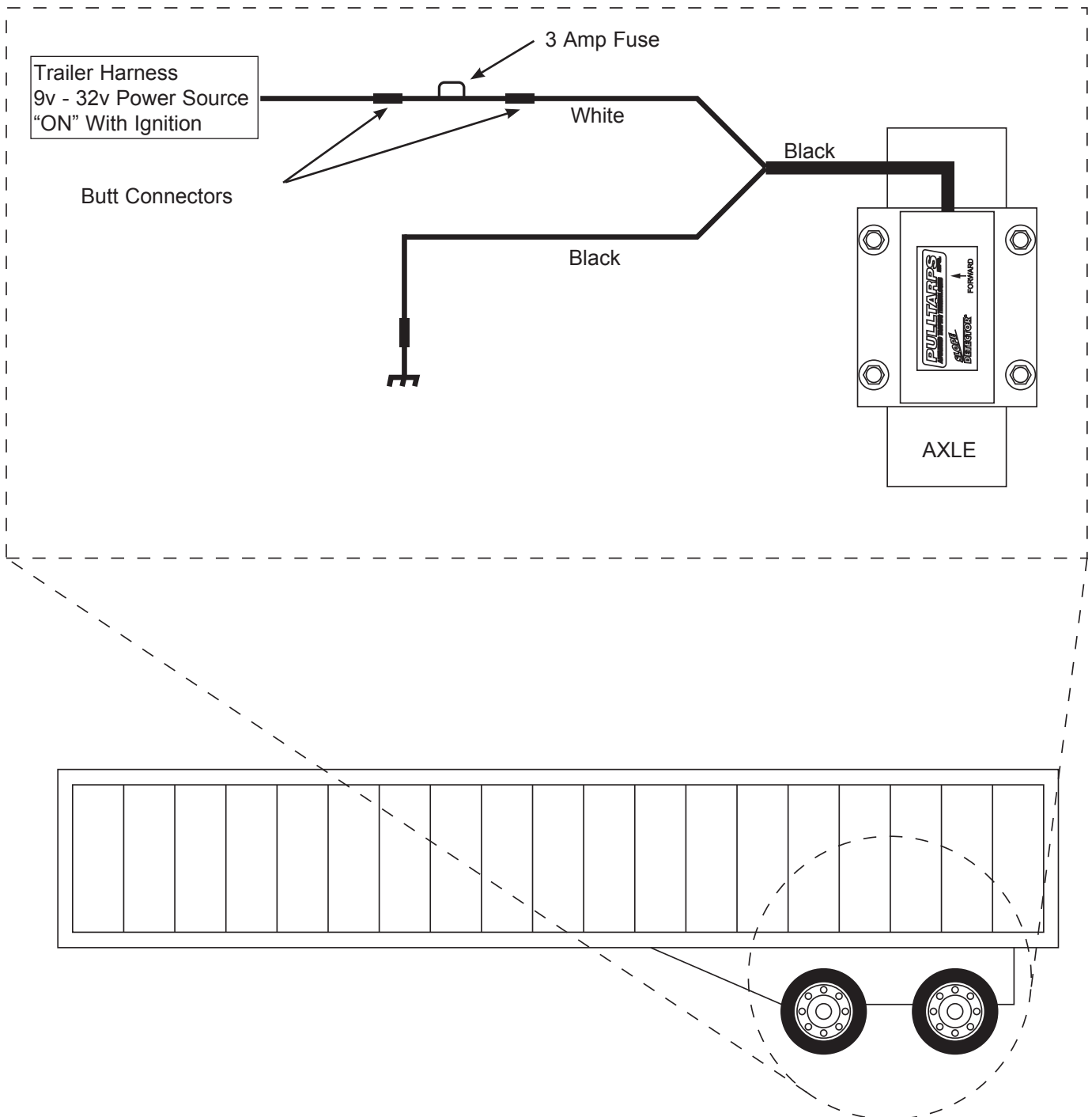

Trouble Shooting Guide

Problem	Solution
THE DISPLAY INTERMITTENTLY READS “Er” INTERRUPTING THE DUMPING CYCLE CAUSING THE TRAILER TO NOT DUMP.	<ol style="list-style-type: none"> 1. THE POWER SUPPLY IS CONNECTED DIRECTLY TO THE BATTERY OR A DIRECT POWER SOURCE IN THE FUSE PANEL. 2. THE POWER SUPPLY IS CONNECTED TO A FAN OR SHARES POWER WITH AN ELECTRIC MOTOR. 3. THE CAB UNIT IS NOT GETTING CLEAN POWER FROM THE CAB POWER SOURCE.
WHEN THE POWER SWITCH IS TURNED ON THE UNIT DOES NOT COME ON.	<ol style="list-style-type: none"> 1. THE FUSE MAY BE BLOWN IN THE POWER SUPPLY WIRE. 2. THE POWER SUPPLY OR GROUND WIRE MAY BE DISCONNECTED. 3. POWER SUPPLY AND GROUND WIRES REVERSED.
THE GREEN LIGHT IS ON INDICATING A LEVEL CONDITION, BUT TRAILER DOES NOT RAISE	<ol style="list-style-type: none"> 1. MAC AIR SOLENOID VALVE WAS INSTALLED IN THE WRONG CONTROL VALVE AIR LINE. MAC VALVE MUST BE INSTALLED IN THE TIP (UP) AIR LINE. 2. MAC VALVES WAS INSTALLED BACK WARDS. 3. DIRT IN MAC VALVE FROM DIRTY AIR LINES. 4. LOOSE WIRE CONNECTION TO THE VALVE.
WITH THE TRACTOR CONNECTED TO A TRAILER THAT DOES NOT HAVE A TRAILER AXLE SENSOR, THE TRAILER WILL NOT DUMP.	<ol style="list-style-type: none"> 1. CAB UNIT MUST BE PROGRAMMED TO “Bp” (SYSTEM BYPASS) TO DUMP A TRAILER WITHOUT AN AXLE SENSOR. <p>System Bypass - During the operation of changing the set-point, if the key is turned to the right and held after 20° the display will read bP, indicating that the system will be bypassed. When the set-point has been programmed for the bP setting, the air line will always be enabled. The system will no longer operate to limit the tilt angle. This setting will allow for the tractor to operate a trailer with no axle sensor unit installed. WARNING: The set point must be reprogrammed when the tractor is again mated to a trailer equipment with a Slope Detector IV.</p>
THE DISPLAY READS STEADY “Er”	<p>THE CAB UNIT IS NOT GETTING A SIGNAL FROM THE TRAILER SENSOR.</p> <ul style="list-style-type: none"> - Check the Fuse on the Trailer Sensor. - Verify the ground on the Trailer Sensor.

Slope Detector IV Parts List

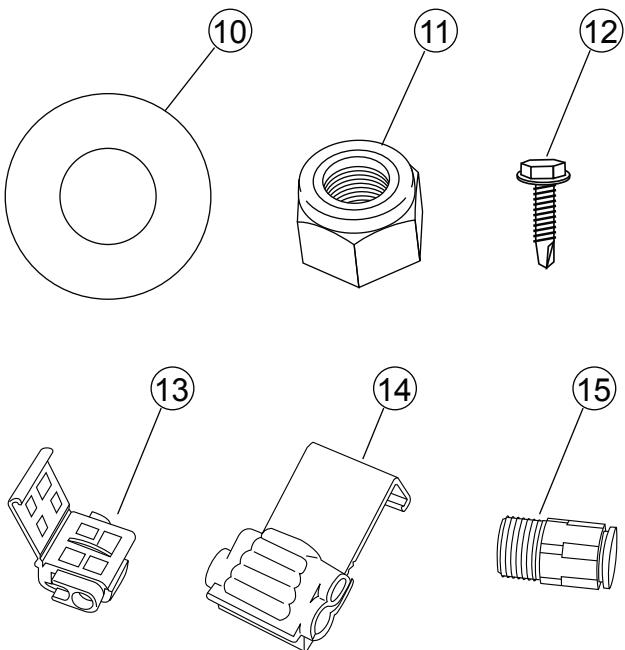
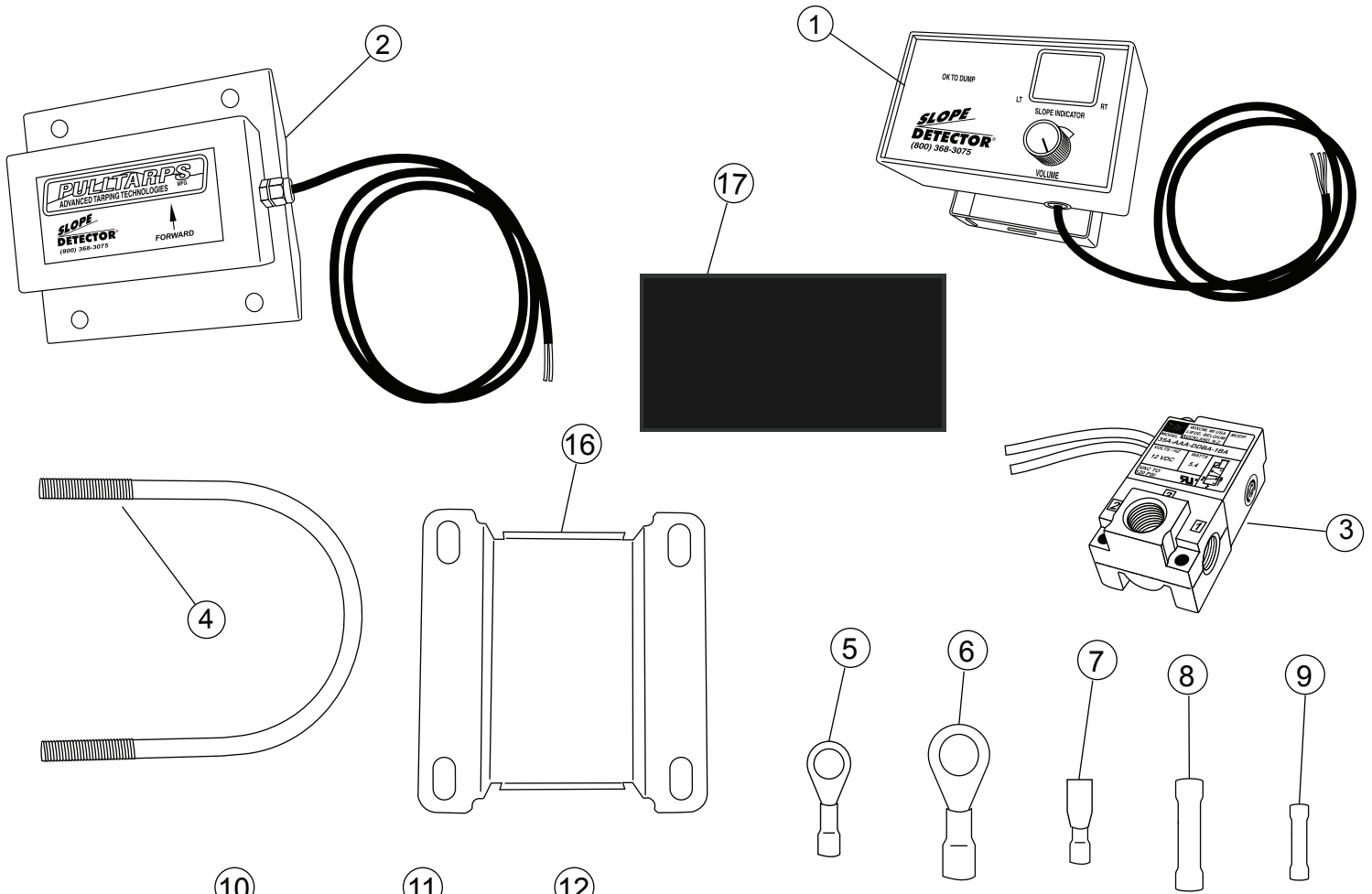

ITEM	PART #	DESCRIPTION	QTY
1	518-0111	Cab Display Unit	1
2	518-0112	Trailer Sensor Unit	1
3	518-0243	Mac Solenoid Air Valve 12V	1
	518-0258	Mac Solenoid Air Valve 24V	1
4		U-Bolt	2
5	514-0320	Connector 16ga. 5/16" Eyelet	1
6	514-0314	Connector 10ga. 5/16" Eyelet	2
7	514-0313	Push-On Spade Terminal	1
8	514-0331	Butt Connector 16-14ga.	4
9	514-0330	Butt Connector 22-18ga.	2
10	505-5004	1/2" USS Flat Washer	4
11	504-5004	1/2"-13 Nylock Nut	4
12	506-9904	#10 x 3/4" Self Drilling Screw	2
13	514-9949	Splice Tap 18-14ga. Blue	1
14	514-9948	Splice Tap 18-10ga. Brown	1
15	517-0332	Air Fitting 1/8" NPT	1
16		Trailer Sensor Cover	1
17		Pad	1